

REVISION					
DRN	CHK	SD	APP	SD	REV
DATE	DATE	DATE	DATE	DATE	NO.
10/08/2021	10/08/2021	10/08/2021	10/08/2021		A
ECR	SD	APP	SD	ECR	A
					210123

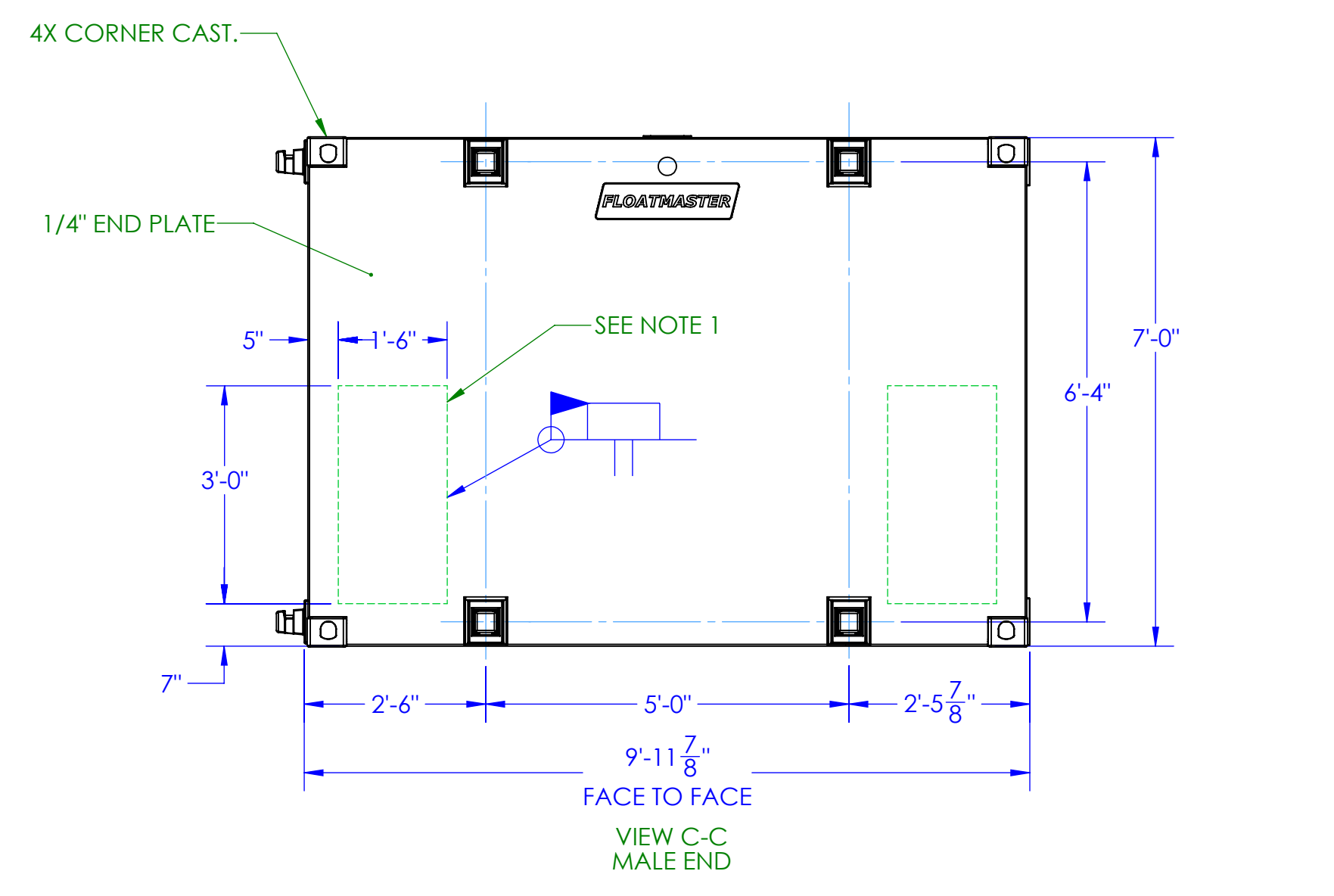
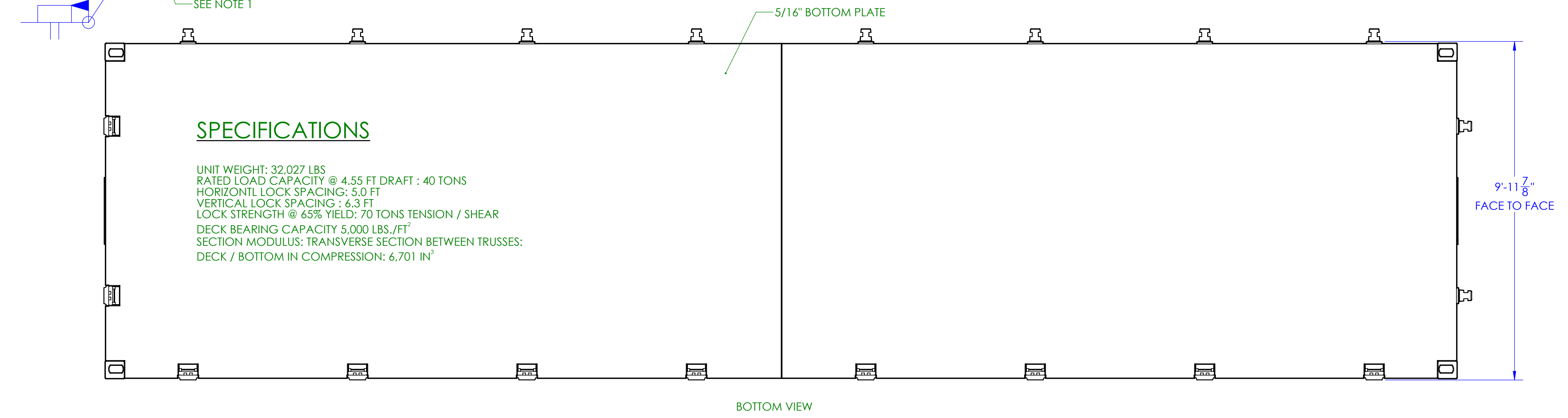
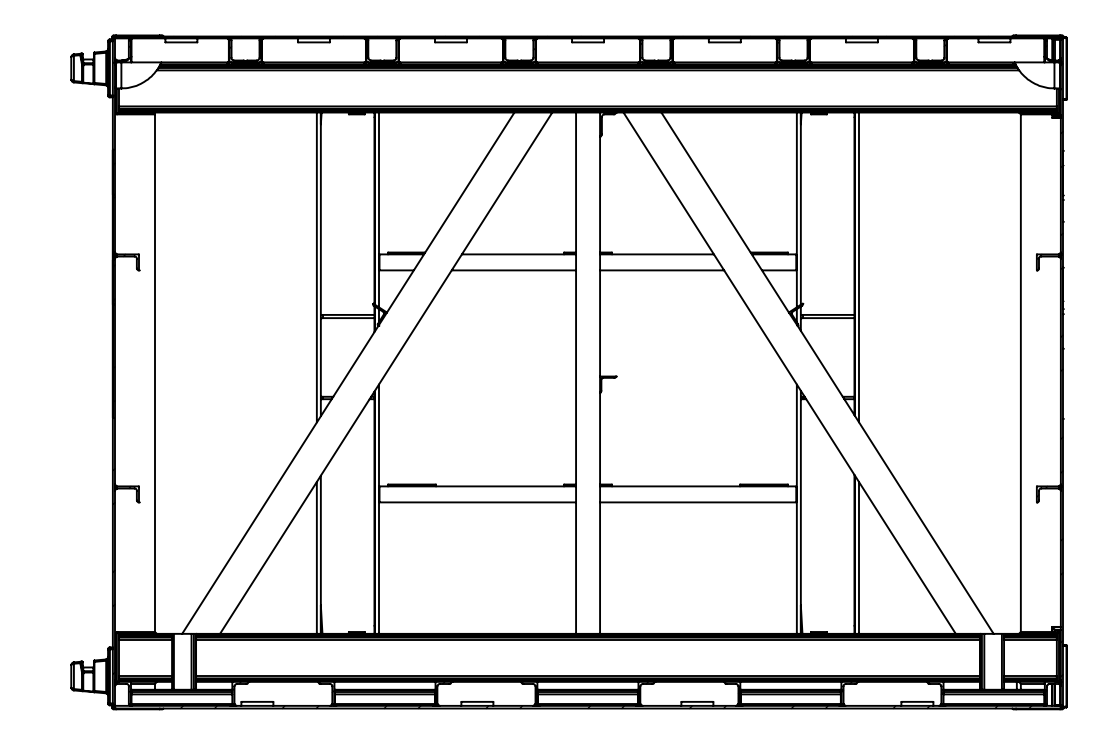
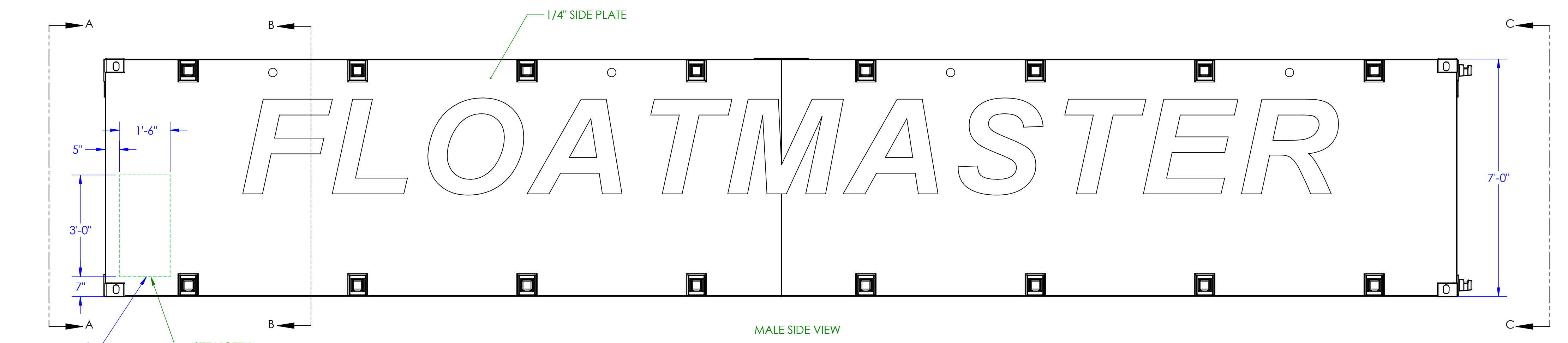
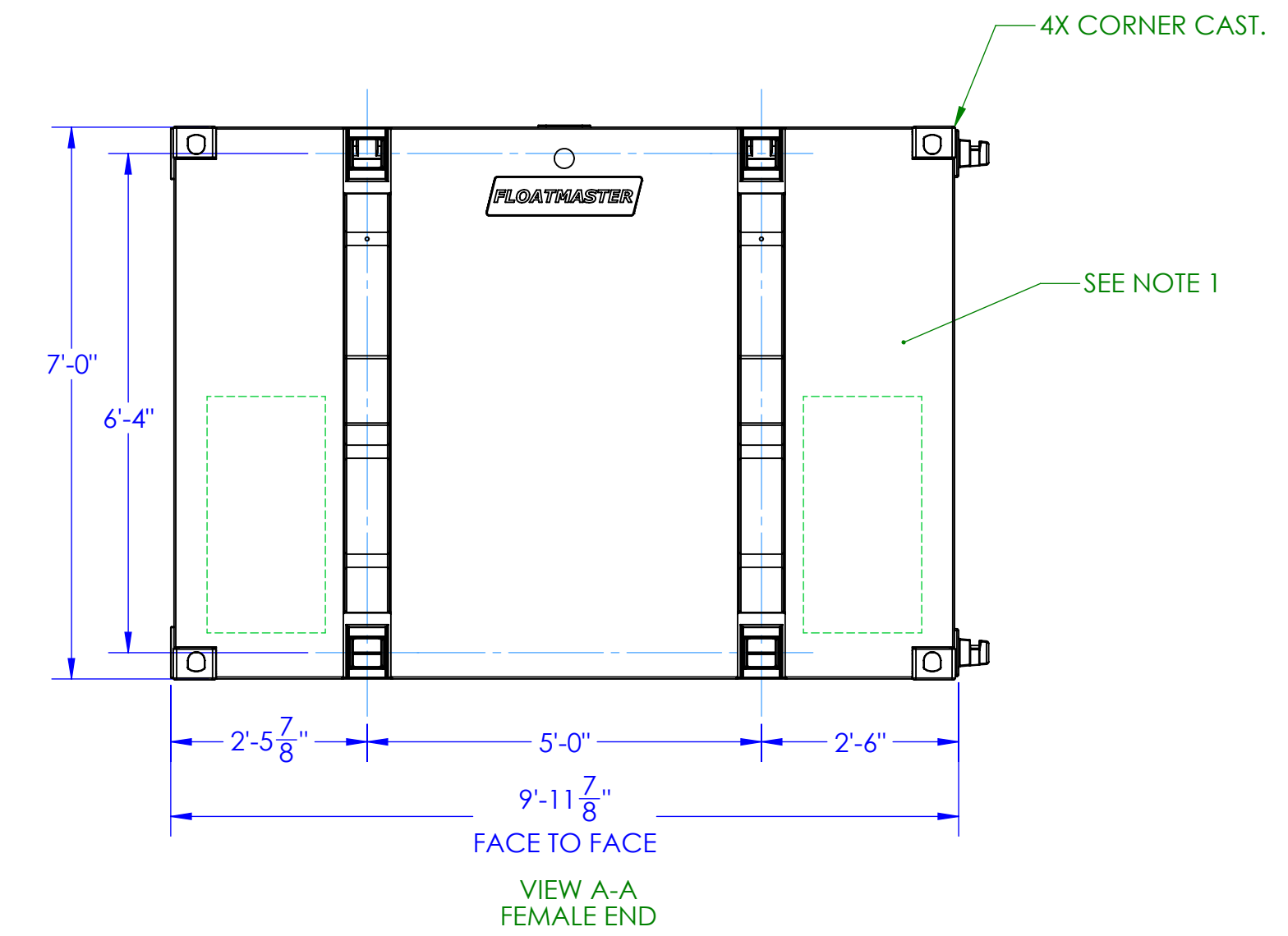
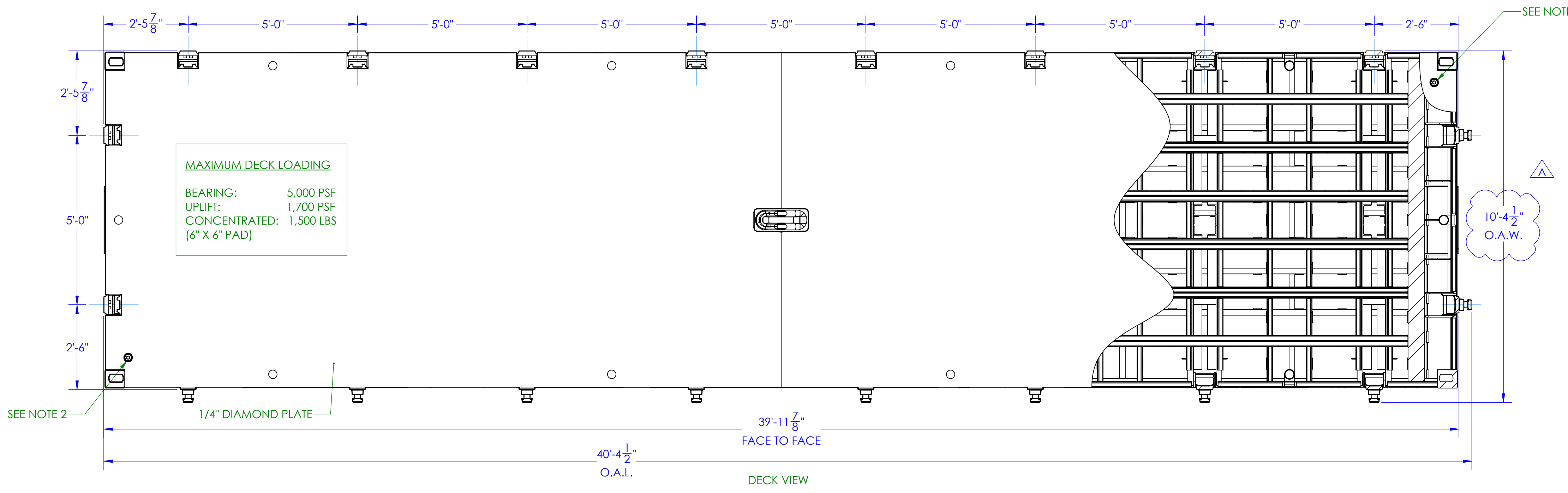

- NOTES:
1. TO ENTER FLOAT FOR INSPECTION OR REPAIR REMOVE FEMALE SIDE CORNER PLATES OR CUT OUT END/SIDE PANELS AS SHOWN. AFTER COMPLETION OF INSPECTION/REPAIR REPLACE PANEL, SEAL WELD, AND TEST FOR LEAKS AS DESCRIBED IN NOTE 2.
 2. TEST FOR LEAKS BY APPLYING INTERNAL AIR PRESSURE OF 3 PSI MAXIMUM. BRUSH ALL EXTERNAL WELD SEAMS WITH WATER AND SOAP SOLUTION. LEAKS WILL BE DETECTED BY FORMATION OF SOAP BUBBLES.

THRUSTMASTER OF TEXAS, INC. GA, FM7400 40' X 10' X 7'

SCALE: 1:24

DIMENSIONING CONVENTION: INCHES (mm)

THIRD ANGLE PROJECTION

EST. WY: 65848

EST. WY: 32046 LBS

PROJECT REF. NO: YS200495

SHEET 1 OF 1